

**EHAD**  
FUEL DISPENSERS

**CATALOGUE**

[www.ehad.co.za](http://www.ehad.co.za)



QUALITY BRAND ACHIEVEMENTS

# M SERIES FLOW METER (ALUMINUM)



**EHAD**  
FUEL DISPENSERS

# 1. Working principle

## 1.0 Working principle for the metering body

M series meter is positive displacement meter for liquids. They are designed for liquid metering both in transfer and process control applications. Thanks to their design they are easy to keep and can suit a wide range of applications. The meter consists of a housing where two bladed displacement rotors and a central single blocking rotor turn in synchronized relationship within three cylindrical bores with no metal-to-metal contact within the meter element. Each rotor is supported on either end by a bearing plate through which the rotor shafts protrude.

The bladed displacement rotors, alternately move through the two half-cylinder bores of the meter element, while the single blocking rotor rotates within its bore in such a way as to produce a continuous capillary seal between the unmetered upstream product and the metered, downstream product.

At one end of each rotor shaft is a timing gear. The blocking rotor gear, having twice the number of teeth of each of the displacement rotor gears, rotates at half the RPM of the displacement rotors.





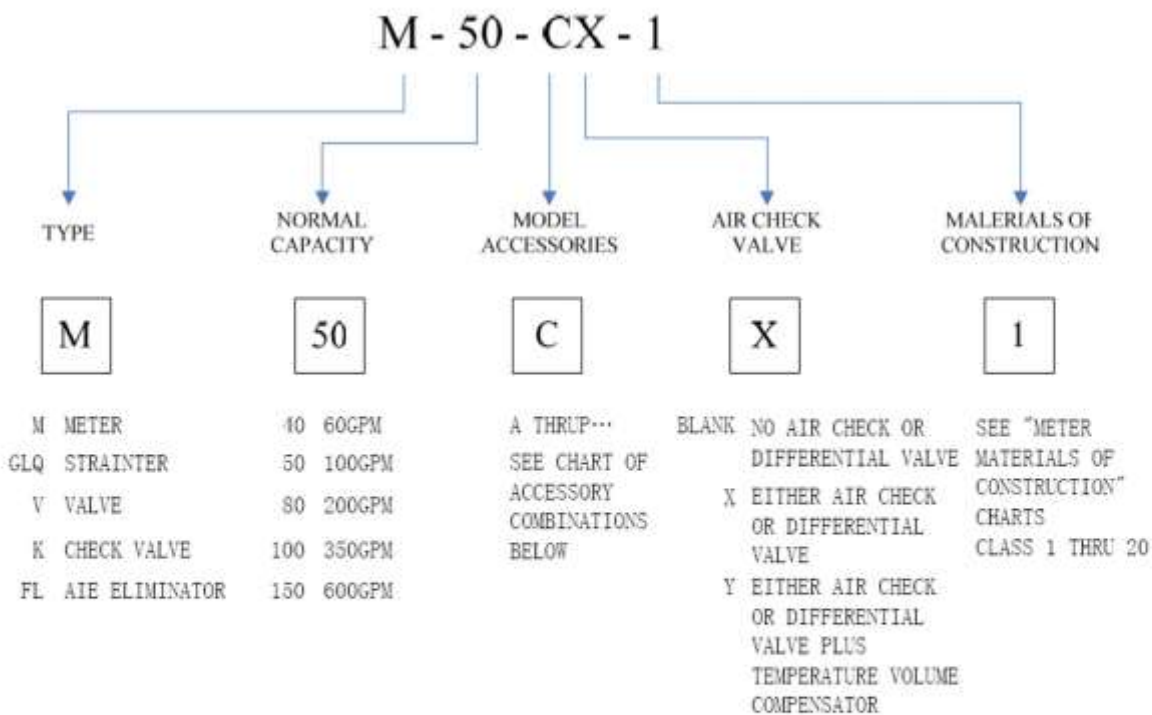





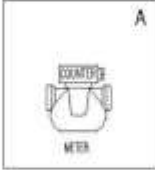
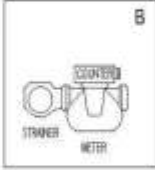
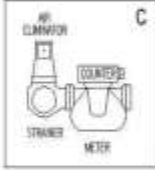
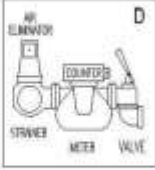

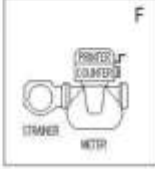
## 2 Model

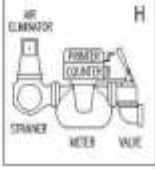
### 2.1 Model Description

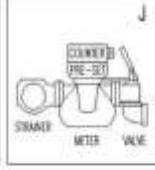
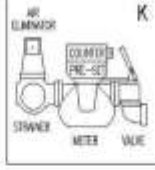

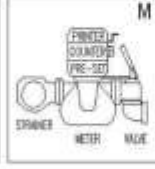
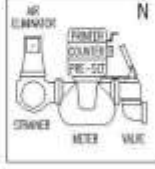
### 2.2 Model Accessories

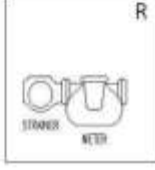
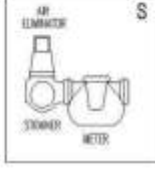
## MODEL ACCESSORIES

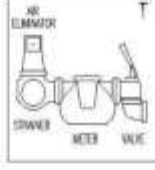
	NO STRAINER NO AIR ELIMINATOR NO VALVE	STRAINER NO AIR ELIMINATOR NO VALVE	STRAINER AIR ELIMINATOR NO VALVE	NO STRAINER NO AIR ELIMINATOR VALVE	STRAINER NO AIR ELIMINATOR VALVE	STRAINER AIR ELIMINATOR VALVE
COUNTER NO PRINTER NO PRE-SET						
COUNTER PRINTER NO PRE-SET						
COUNTER PRE-SET NO PRINTER						
COUNTER PRINTER PRE-SET						
NO COUNTER NO PRINTER NO PRE-SET						

### 3.0 Typical Application:

- Check of loading/unloading operations of fuel and petrochemical products in fuel bulk plants and/or refineries
- On truck tanker for fuel/LPG transport and delivery
- Heavy duty fuel dispensing system for big vehicles and airplanes

#### Typical Application of Aluminum Construction

Class 1 meter: refined petroleum products, such as gasoline, fuel oil, diesel fuel, kerosene, ethylene glycol, motor oils and rotogravure ink.

Class 2 meter : aviation gasoline and jet fuels.

Class 3 meter: a wide variety of products such as: liquid sugars, corn syrup, corn sweeteners, dextrose, fructose, sucrose, maltose, lactose, corn oil, soy bean oil, cotton seed oil, coconut oil,





Attention: every part of the piping which could stop and/or isolate the flow should be provided with a pressure relief to prevent damages from thermal expansion.

- Upstream lines must be maintained full to prevent air from entering the meter. If the upstream or inlet lines are constructed in a manner which allows reverse flow, foot valves or back checks must be installed
- Underground tanks that are furnished with a submersible pump will eliminate many problems that occur with positive displacement pumps (suction pumps) when suction piping is incorrectly sized or when the lift is too great.
- Give careful attention to your system's pumping equipment and piping because of their influence on liquid being measured as it enters the meter assembly. Systems should be made free of conditions that cause or introduce entrained air or vapor
- Follow the manufacturer's recommendation fully when installing pumps. Give particular attention to factors like: use of foot valve, pipe size to the inlet and conformance to net positive suction head conditions when suction pumping is required.
- For volatile liquids, such as light hydrocarbons which tend to flash or vaporize easily at higher ambient temperatures, it is desirable to use flooded suctions and piping sized large than the normal pump size
- When locating the meter under a tank (on truck tankers) the course of the suction piping affects metering precision. The piping should have a constant inclination towards the pump avoid goosenecks
- Hydraulic shock is harmful to all components of an operating system including valves, pump and the meter. In particular meters must be afforded protection from shock because of their need to measure with high precision. Generally the best protection is prevention, which can be readily accomplished by adjusting valve closing rates in such a manner that shock does not occur.
- Thermal expansion like hydraulic shock is a phenomenon that can easily damage meters and systems in general. Care should be taken in designing the system to include pressure relief valves in any portion or branch of the system that might be closed off by closure of operating valve or block valves
- The meter can operate in a dry condition (with no liquid) for no longer than 5 minutes
- The meter shall operate within the recommend flow rate range. Only in some exceptional events it may be allowed to let it work with a 20% higher flow rate than the nominal one and only for a short time.
- Start up during the starting up the system shall be slowly filled in with liquid. There shall be no air in this phase. Take care not to damage the meter. The system should be filled in by gravity or by using a pump
- Filling in the system by means of a pump. Apply to the pump manufacturer for information about its loading. After the pump has been loaded with liquid, operate as follows:

Make sure the downstream valve is shut down

The meter counter will start turning

When the meter has started counting volume open completely the valve

In this phase the meter should not run faster than 20% of its rated flow. Once the product is flowing out the end of your system, the outlet valve can be opened all the way provided



and shortening's etc. rate of flow is based on viscosity to pressure loss relationship.

Class 10 meter: liquefied petroleum gas(LPG) including butane, isobutene, pentane, ethane, freons and propane.

Class 14 meter: crude oil, also for heated and/or viscous liquids including animals fats, resins, #6 oil and non-abrasive asphalt emulsions.

Class 15 meter: for metering oil or water based latex products, polyester resins, and adhesives (neutral pH). also available for metering herbicides and nitrogen fertilizer solutions (requires Viton and Teflon seals).

Class 16 meter: for general solvent metering, such as methanol, toluene, xylene, naphtha, acetone, MEK, MIBK, and alcohols including ethanol.

## 4.0 Technical data

Flow rate: M-40-1 1-1/2" 23L-230L/min  
M-50-1 2" 38L/min-380L/min  
M-80-1 3" 76L/min-760L/min  
M-100-1 4" 130L/min-1300L/min  
M-150-1 6" 230L/min-2300L/min

Max Pressure: 10Bar

Standard measure unit: Liter and US Gallon for option

Repeatability: 0.05%

Type of flange: ANSI, NPT, BSPF

Strainer mesh: 80Mesh for diesel, 40Mesh for gasoline.

## 5.0 Installation requirement

- Make sure you observed all of safety rules concerning room ventilation, temperature control, fire prevention and fire extinguishing systems
- Make all connections in order to ensure the meter and grounding device system are equipotential.
- Make sure you can get easily to fire extinguishers for your product. Consult your local fire department for proper information about fire problems and mandatory law dispositions
- Install the meter and its accessories complying with the electric and safety standards in force.
- Prior to meter installation the entire piping system must be flushed, with a liquid that is compatible with the construction of the meter
- Keep the meter external surfaces clean in order to notice easily possible defects
- The meter must be firmly fastened to a platform or other support regardless or its mounting position. Never hand the meter to the piping system and do all necessary to





avoid that piping tensions due to such cases as material dilation by temperature, stress of flange screw, etc. Are conveyed to the meter assembly. Expansion joints both at the inlet and outlet of the meter assembly will prevent it from these tensions

- Calculate suitable working areas for maintenance operations. Remember you need a support where to mount the meter
- Meters are designed with special materials depending on the liquid/s they are used. Their compatibility with a certain class of liquids is indicated on the M series tag. Meters should not be used with other liquids. In case of doubt please apply to M series for information
- If required, convey the piping downstream of the meter towards a bank prover in order to carry out calibration and/or metrological check
- When missing in the assembly install a suitable strainer upstream of the meter so as to strain every foreign material (welding dross, dirt etc.) Foreign bodies over a certain size could get into the rotors and cause them to seize.
- When the meter assembly has got an air eliminator you have to connect the two outlet threaded ports (or just one when the assembly includes an air check valve) to the tank of the liquid which is metered or to other sealed container under ambient pressure. This to avoid contamination of the surrounding
- There is a mutual relationship between the liquid flow direction in the meter and the correct indication of the delivered quantity on the register display; if you desire the register to count down you will have to reverse the position of the adjuster drive gear.
- New or repaired piping can be the source of welding dross or foreign material which clog or break the strainer network. The strainer basket must be daily checked during the first 100hours of operation
- A frequent check and cleaning of the strainer are required in order to get a good performance. Locate the strainer on the inlet side of the meter. Screw the strainer firmly to the meter flange. Fasten the piping to the strainer
- The meter and its accessories must not support the weight of piping system. There is enough room to remove the air eliminator
- Locate the air eliminator on the inlet side of the meter. Always mount the air eliminator in vertical position. Screw the air eliminator to the coupling flange of the strainer. Connect and fasten the piping to the air eliminator.

## 6.0 Operation requirements

- The meter must remain full of product at all times. An easy way to accomplish this is to put the meter assembly in the line below the piping centre-line. This requires adding elbows and flanges prior to installing the meter. The meter should be installed in a bypass loop, below the pipe centre-line, with block valves upstream and downstream. A block valve should be located in the mainstream, labeled as the bypass valve. Mounting the meter like this allows to keep the meter always full of liquid and to isolate it for servicing or calibration when required, while continuing flow through the bypass-valve.



that the system is designed not to exceed the flow rate marked on the meter

- Never use the meter or the system when they are not completely full of liquid or in presence of air bubbles or compressed air/vapour. If this is not possible you require devices to eliminate air/vapour.

## 7.0 Troubleshooting

ITEM	TROUBLE	CAUSE AND SOLUTION
1	Leakage from the lid seal	The seal has been damaged by pressure or bolts have been screwed incorrectly
2	The product flows through the meter but is not counted by the register	A. Check the packing glands and gears B. If all parts work properly the problem is to be found in the register which is defective and should be checked and repaired
3	Gear cogs are broken	Sharp flow variations
4	The product flows through the meter but the register does not work correctly	A. The register has not been adjusted correctly B. Wrong gear plate ratio or wrong installation of a gear on the plane
5	The meter operates slowly	The internal valve gear is defective. The valve doesn't open correctly
6	The blocking and displacement rotors do not turn	A. Breaking of the strainer basket likely due to improper maintenance. Replace the strainer basket and follow maintenance procedures. Clean out the meter and its parts B. The basket got dented so as to cause leaks which allow the intrusion of strange bodies. Replace the basket C. Blocking and displacement rotor are blocked. Call the service company.
7	Leak of product from the strainer lid	A. the trouble may be due to seals which are damaged or worn out. Replace the seals. If they are Teflon made replace them even if still in a good condition. B. Dirty surfaces which prevent a perfect sealing by the gaskets. Clean out the gaskets housings.
8	Pressure drop in the strainer or flow decrease in the meter	A. the basket network is clogged by intruded material. Clean out the strainer body and basket B. the basket network size does not fit the liquid viscosity. Replace the basket with a new one having a proper net size (thicker or looser, with more or less "meshes")
9	The floater in the air eliminator is crushed	The crushing is due to water hammers, the floater is always in the position of open slots, letting the





		liquid leak from them or in the position of closed slots, letting air and vapour go through the meter. Beware water hammers and replace the floater
10	The floater in the air eliminator is punctured	As time goes by the floater can get punctured and fill with product when operating, so that it gets heavy and remains in the position of open slots. This causes the product to leak from the slots. Replace the floater
11	The reeds in the air eliminator are worn out	There is not a perfect sealing with the slots. This cause the product to leak. Replace the reeds.
12	The product leaks from the air eliminator lids	The gaskets or the rubber coated plates are worn out. Replace the plates or the gaskets.

## 8.0 Dimensions

### 8.1 M-40-1 Meter Dimension

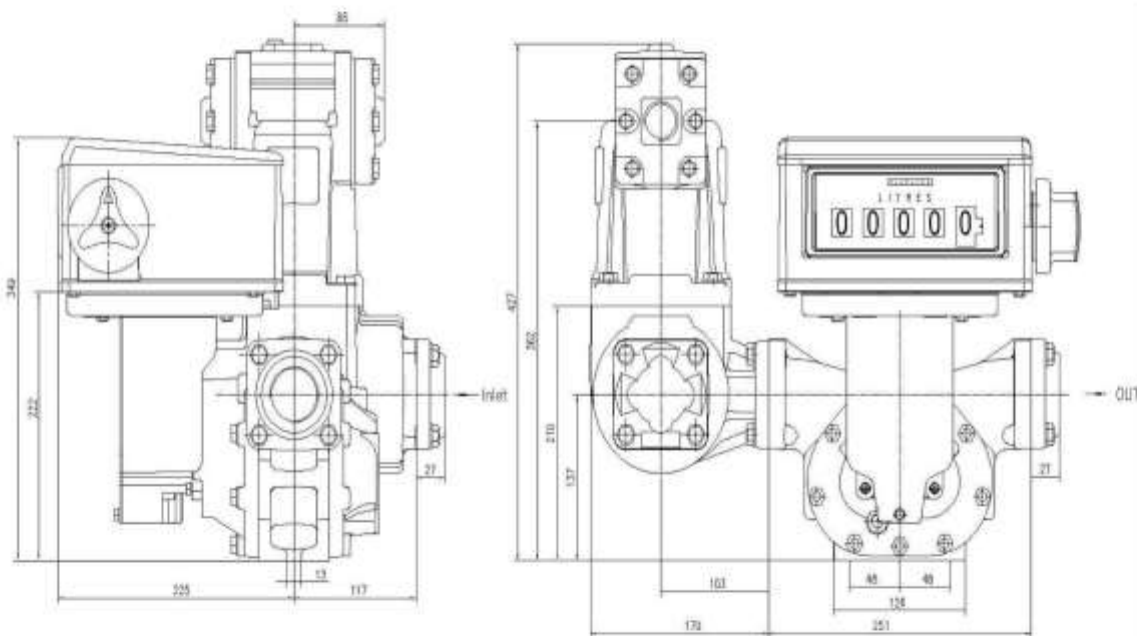

### 8.2 M-50-1 Meter Dimension

